

Energy Efficient Electrical Design for a Higher Education Building

Matthew Cobb, Nathan Justin, Adel El Shahat

Department of Electrical Engineering
Georgia Southern University
USA

ABSTRACT:

This paper encompasses the design and development for an energy efficient electrical design of a commercial structure for a post-secondary academic institution. Electricity is used every day across the world at ever increasing consumption levels. The goal of this work is to design a complete and safe electrical system that reduces power consumption and increases user friendly operation of all high and low voltage equipment for the end user of the building. Computer Aided Design (CAD) and Building Information Modeling (BIM) tools are used to design and model the electrical systems. In this paper, a step by step process has been stated to accomplish each task so that the final completed design is a success. Background information, goals, and methodology are included with supporting material to present the reader with evidence that this design has a high probability of achieving all expectations. We designed the device and equipment layout of the floor plans for each type of electrical system. The next step is to perform all electrical load and lighting calculations using Microsoft Excel and Acuity Brands Visual 2012, respectively. Furthermore, three dimensional modeling of components within the building environment is presented. Schematic floor plan layouts on 30" x 42" architectural sheets along with highlighting important points from our technical specifications will be introduced and presented as well. We also present simulation results obtained from the lighting analysis software and to demonstrate the completion of the power distribution diagram, the lightning protection design and all technical detailed installation drawings in AutoCAD MEP and Autodesk Revit. For the final demonstration, the plan is to present the final hard copies of all designs and all technical supporting materials.

KEY WORDS: Design, Building, Efficient, Modeling, Education.

I. INTRODUCTION:

Humans have always strove to create shelters. The earliest forms were naturally occurring caves. We then learned how to construct basic structures to shield us from the elements. As technology advanced so has the complexity of the structures we created. In today's society buildings are very complex and have many different systems implemented in them. Some of these systems include heating and air, fire alarm systems, elevators, data systems. Each of these systems have numerous standards that must be adhered to in modern day buildings. The National Electric Code has thousands of pages of regulations that include the tiniest of details. The most important thing that must be kept in mind when designing a building is safety. All calculations must be completely correct because the general public will be at risk something malfunctions. That is one of the main reasons the NEC was created in the first place. All buildings must have exits and alternates routes. They must also include fire alarms, max occupancy data. Typically most electric designs are completed by consulting companies. These consulting companies work directly with the architect and then sometimes with the contractors who do the actual construction

of the building. The architect will design the building according to what the customer specifies and their individual needs. The consulting company will then talk with the customer about what is going to go inside the building. This could include heavy machinery, classrooms, or anything else that requires electricity. Depending on the size of the building and the complexity, there could be one or two people working on the project or an entire team. The lengths of the projects also vary depending on the building complexity and size. The firm then places components on the floor plan sheets. Then the calculations are made in order to size the panels that will be required. By the end of the process everything from transformer size to wire size is specified. This information is given to the contractor along with numerous other specifications. The contractor then constructs the building and returns "as built" markups on the plans to the firm. Sometimes when the building is being completed components must be moved slightly. These are usually slight changes like a receptacle being moved one foot over.

In today's advanced society and governments buildings are regulated. There are many organizations that have developed over the years that deal with different aspects of building regulations. The National Fire Protection Agency is one agency that is highly involved with all building structures. The American Society of Heating, Refrigerating, and Air-Conditioning Engineers is another organization that governs the energy requirements for buildings. The Building Industry Consulting Service International is another organization that sets best practices standards of how telecommunications in buildings are designed and installed.

The National Fire Protection Agency was created in 1896. The NFPA is mainly a United States agency that creates the standards and codes for all buildings. It was created in order to standardize the new usage of fire sprinkler systems in buildings. Since its creation the codes have evolved and expanded to more than just fire sprinkler systems. The code they create and maintain includes building codes and regulations regarding equipment utilized by firefighters. Today they maintain and update 380 different codes and standards. All of the codes are designed for one purpose and that is the safety of the buildings occupants.

The American Society of Heating, Refrigerating, and Air-Conditioning Engineers was founded in 1894. The main purpose of ASHRAE is to govern how new buildings are sustainable and to limit the environmental impact for the future. ASHRAE 90.1 is the standard that deals with energy requirements that were encountered with this project. This table has been updated many times in recent years to reflect changing technologies. 90.1 includes requirements for insulation, power, lighting and numerous other parameters.

The Building Industry Consulting Service International or BICSI is an organization that sets standards for the telecommunication cabling in buildings. This organization was formally created in 1977 and it was originally just a meeting of different Building Industry Consultants, BICs. The original purpose was to meet and discuss how to improve in executing their jobs. It eventually turned into an organization that set standards for how telecommunications in buildings are installed and maintained.

This type of electrical design is typically done by Engineers in Training, Engineers who have passed the FE exam, or Professional Engineers. Professional engineers are engineers who have a special license in a given state which shows that they are trusted by the state to approve designs. Depending on the size of the project an E.I.T might do all of the designs and only have the final plans checked and stamped by a P.E. Bigger projects require more people working on it as well as more professional engineers. All designs must be checked and stamped by a professional engineer. The P.E. that stamps the final plans is the person who is held responsible for making sure all the calculations and designs are correct and in accordance with all code.

II. TECHNICAL DESIGN:

This section is intended to outline the technical criteria in which the system has been designed, and it also

provides execution standards for the skilled trades to which this electrical system must be built. Note that this section is also typically submitted along with the schematic and detail drawings to the architect so that the various contractors can properly estimate and bid this design. This is all part of the design-bid-build process outlined by the American Institute of Architects. Specification sheets will only be included for lighting fixtures in the appendix (coordinated with light fixture schedule) because various options for electrical equipment manufacturers and models are provided in this section.

Division 27(low voltage)equipment will be furnished by building owner and installed according to appropriate floor plan schematic layout by low voltage licensed contractor. The specifications for routing and wiring low voltage cabling is included in this section as applicable by the National Electric Code, BICSI, and EIA/TIA.

III. SIMULATION:

The simulation of this project was done in two parts. The simulation was used for the point by point lighting analysis. In order to fully understand how the lighting analysis is done we must first look at the basic method to lighting analysis. We used the zonal cavity method in order to generate a rough estimate before simulating each room with the Visual 2012 software. The zonal cavity method is a method that is used to accurately calculate the illuminance of a room. There are three spaces in a room. The first is the ceiling cavity, the second is the room cavity and the last is the floor cavity. Each cavity has its own cavity ratio. This ratio is determined by the dimensions of the area being calculated. Here is a basic formula for calculating a generic cavity ratio.

$$\text{Cavity Ratio} = \frac{2.5 \times \text{height of cavity} \times \text{cavity perimeter}}{\text{area of cavity base}}$$

Fig.1. General Cavity Ratio Formula

Once the cavity ratio is determined the cavity reflectance must be evaluated. These are values then used to determine the Coefficient of Utilization. This coefficient is used to determine how many lamps are needed in a room if given a goal foot-candle value. For this project we used a goal of 50 foot-candles for the classrooms as well as 80-50-20 reflectance values for ceiling, walls, and floors. These are commonly used values and work in most buildings. The reflectance values must be converted into effective reflectance values. These values are then used in conjunction with a table to look up the coefficient of utilization. Then an equation is used with other parameters such as the number of lumens per lamp, CU, area of the room and desired foot-candle level.

$$\text{Footcandles (maintained)} = \frac{\# \text{ of fixtures} \times \text{lamps per fixture} \times \text{lumens per lamp} \times \text{CU} \times \text{LLF}}{\text{area in square feet}}$$

Fig. 2 Foot-candle Equation

In order to do all of the calculations for the numerous rooms for the building we used an excel spreadsheet. We entered in the dimensions of each room, the room cavity ratio, specific information for each light fixture. We also entered in our target foot-candle value for each room. The spreadsheet then returned the number of fixtures that would be needed in each room in order to reach the specific foot-candle level. After all of the rooms are uploaded into the spreadsheet we can get a number of light fixtures for each room. We then place all of the lighting fixtures onto the plans according to NEC regulations. Using the excel spreadsheet we can get a very close estimate for the foot-candles in each room. In order to get a more in depth lighting analysis we use Software. The software we used is Visual

2012. The process for the software was different than that of using the excel sheet. When doing the simulation there are only a few parameters that are needed. They are the number of fixtures in each room, the lighting fixture file, and the dimensions of each room. Once all of these values are known the simulation can be started. Each room is created according to the dimensions. Then the lighting fixture file is uploaded and the number of fixtures. At this point the fixtures are in the room and we can simulate a 3D picture of the room. This image shows point by point analysis as well as the average of the whole room. With this view we can see where the most light is concentrated. The only number that is important though is the average number of foot-candles in the room. We use this and compare it with the number generated by the excel spreadsheet. Here is the same room in the excel sheet and the simulation.

ROOM I.D.	FIXT. TYPE	ROOM SIZE L W	CEILING HEIGHT	AREA F ²	CAVITY HEIGHT	RCR	No LAMPS	WATTS	VA	CU	MF	LUMENS/ LAMP	No FIXT.	TARGET FT-C	CALC WATTS	CALC VA	INTERPOLATOR RCR	CU	
122 EC CR	B1	24.0 22.0	10.0	528.0	7.5	3.3	2	62	72	0.53	0.9		9.3	50			3.0	0.55	
												NORMAL ----->	2950	9.0	48.3	558	648	3.3	0.53
												EMERGENCY ----->	1350	1.0	1.2			4.0	0.49

Fig. 3 Room 122 Excel

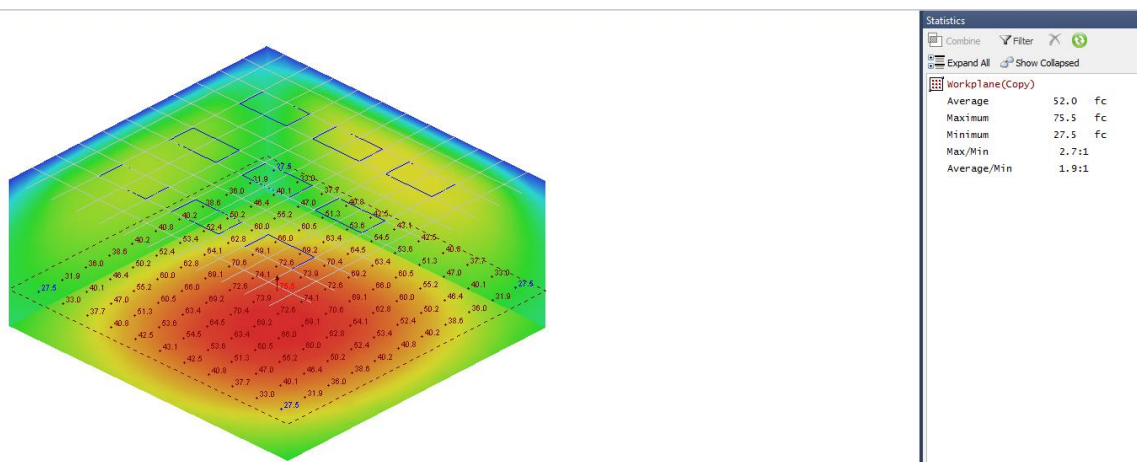

Fig. 4 Room 122 Simulation

There is a slight difference between the excel calculation and the simulation value. The Excel average value is calculated to be 48.3 foot-candles and the simulation gives an average value of 52 foot-candles. The simulation gives a more precise value and also shows the concentration of light in each area of the room. The excel formula is only used to give an estimate so there is a reference as to what the simulation should give as a result.

IV. IMPLEMENTATION:

This project had many different steps before it was actually realized as a finished product. The very first step was to decide on the project. Once Electrical Design was accepted and allowed for the senior project we had to decide what would be a suitable size for the project. This was the building selection portion. We wanted to have a building that was big enough and complex enough to be a challenging project. We also needed the project to last the span of two semesters. We ended up selecting a building that would be very similar to any building on most small college campuses. It is a two story educational

building with many classrooms and offices.

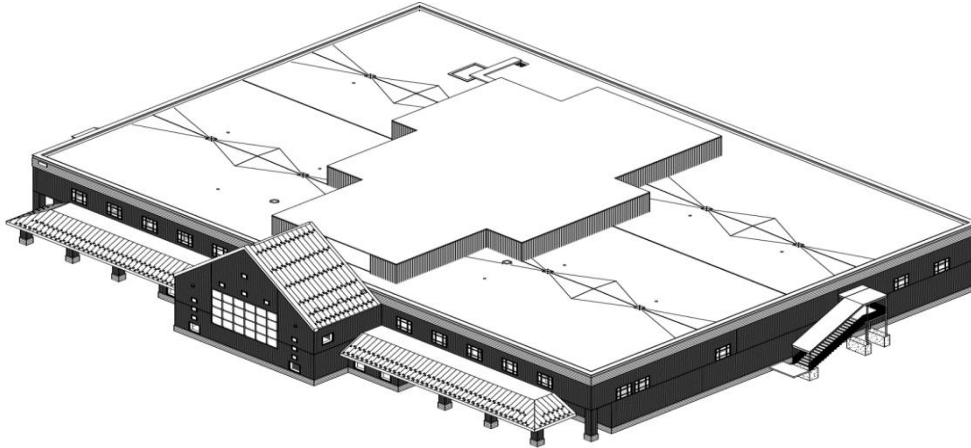

Fig. 5 Building Structure

Once the building was chosen the next step in real application would be to talk with the customer about what kind of components would be in the building. This includes anything that using electricity. We need to know what rooms to place these components and the electrical requirements so we can circuit and correctly size all of the panels that will be in the building. Once all of the components are known we place all the components on the layout in Revit. Component placement can take a large amount of time because everything must be in compliance with NEC code and there are multitudes of components. All of the lights, smoke detectors, fire pull stations, power and data receptacles, floor boxes, audible and visual alarms, and wireless access points must be placed within regulation. Anything that consumes electricity must be placed in accordance to a code that is set by the NEC or best practices standard by BICSI. Below is an example of the components in a typical room. The lights are not displayed in this view because there is a separate lighting sheet. The figure below shows floor boxes with duplex receptacles and telecommunications outlets, wall duplex receptacles, wall telecommunication boxes, a ceiling mounted telecommunications junction box as well as ceiling mounted duplex receptacle, and a motor load for the projector screen.

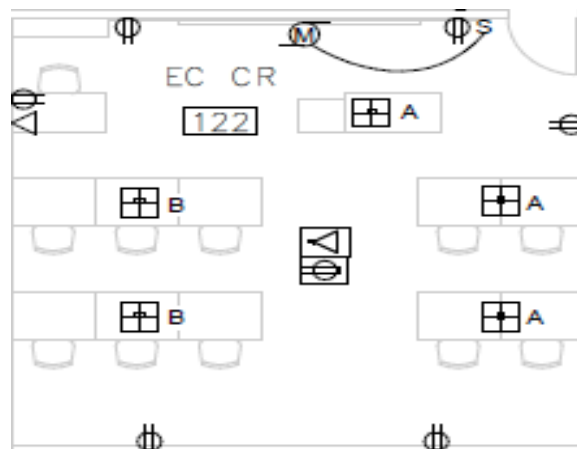

Fig. 6 Components Placement Example

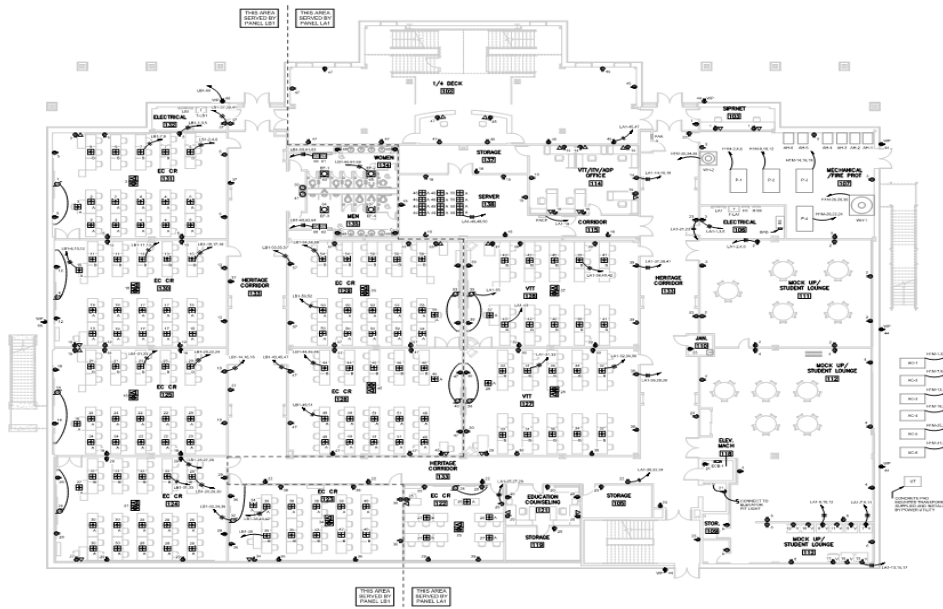

Fig. 7 First Floor Power Plan

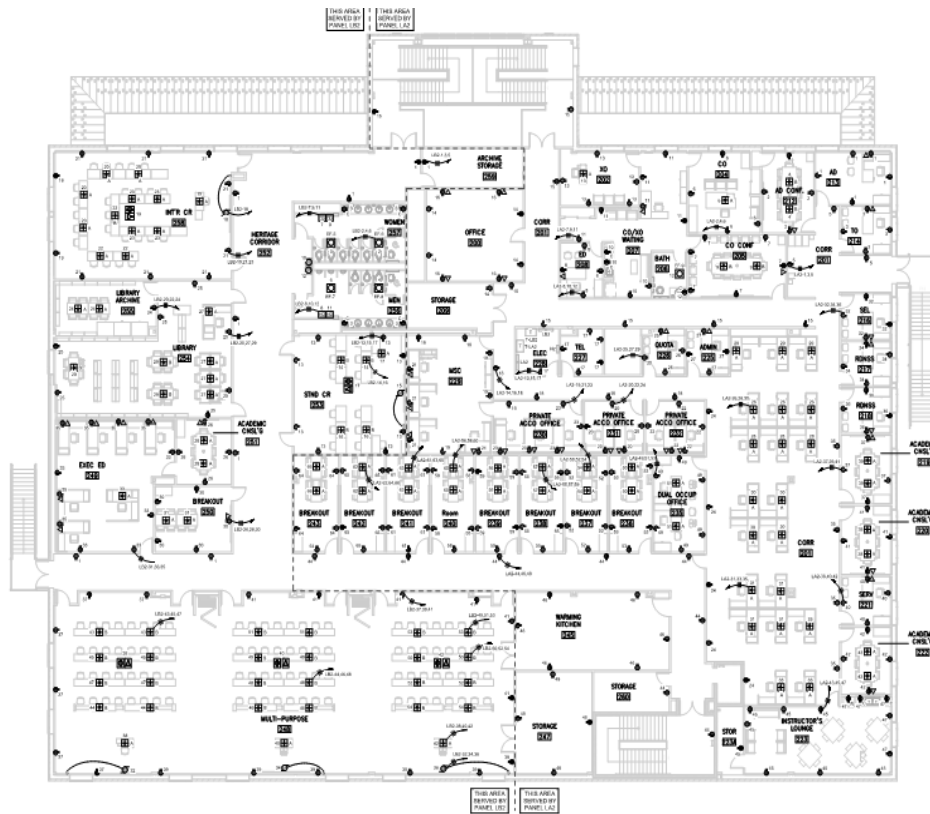

Fig. 8 Second Floor Power Plan

The following is the appropriate circuiting information that is coordinated between the power plans and each respective panel schedule. Branch circuits on 208/120V that are 20 amp single pole trip can handle $20A \times 120V = 2400VA$. Because of the variations of the time-current trip curves of molded case thermal magnetic circuit breakers, we shall take 80% of this load which gives 1920VA. Because of the distinct possibility that every one of the electrical devices on this particular type of circuit may be running continuously for at least three hours (NEC definition of continuous), we shall take another 80% of 1920VA leaving each 20A and 120V single pole branch circuit with an approximate max loading of 1536VA. The same process is followed when a larger than 20A single pole circuit is used or for panels of 480/277V. Method for Designing Power Distribution is as the following:



Fig. 9 Panel LB2 Example

The Panel LB2 has a total three phase connected load of 64,382 VA. Panel LB2 is a 208Y/120V connected panel which means $64,380 VA / (208V \times \sqrt{3}) = 178.7A$. This requires the Panel LB2 main breaker to be rated at 200A.

With a connected load of 64,382 VA, this requires the isolation transformer to be rated at 75 kVA. The National Electric Code requires that the primary side of delta-wye transformers be protected at 125% of the transformer rated current. If no breaker size matches this current value, the next standard size up shall be used.

$T-LB2 = 75,000 VA / (480V \times \sqrt{3}) = 90.21A$; $90.21A \times 1.25 = 112.76A$ (NOT A STANDARD BREAKER SIZE SO 125A O.C.P.). Using the following NEC table, the current carrying conductors can be sized (as well as 100% neutral where required). Note that THHN insulated conductor has been specified and is rated at 90° C, but the lugs on the panels will be 75° C so the ampacity of the THHN must be de-rated to 75° C. This design and reference procedure is repeated for all panelboard feeder conductors and required transformers when necessary.

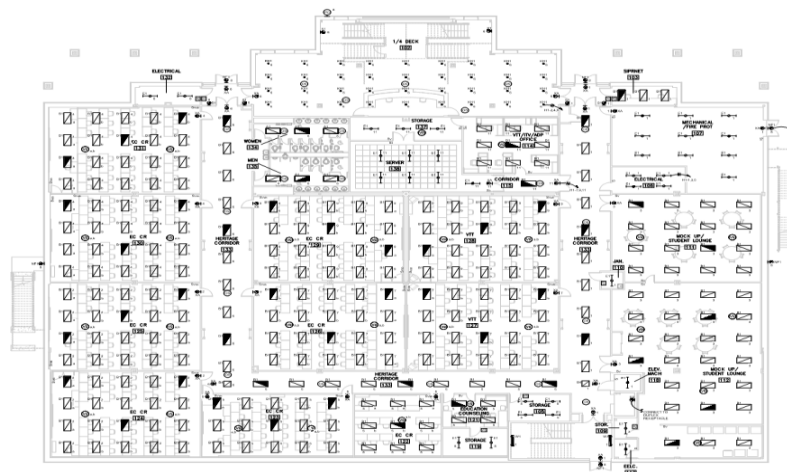

Fig. 10 First Floor Lighting Plan

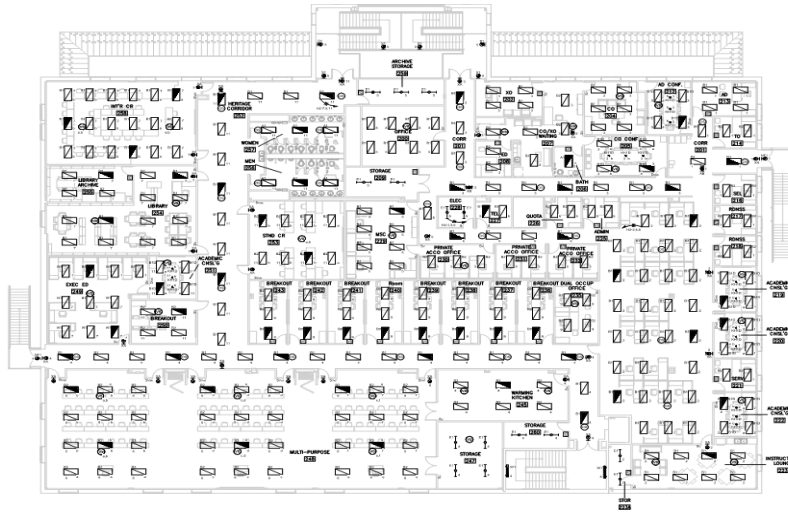

Fig. 11 Second Floor Lighting Plan

All lighting fixtures shall be wired and circuited at 277V (Line-Neutral) single phase to the H1 and H2 Panels, respectively. Occupancy sensor switching is used in corridors and restrooms. Vacancy sensor switching is used in every other room with the exception of electrical rooms, mechanical rooms, communications rooms, janitor closets and other very small storage closets. These exceptions can house normal toggle switches with safety in mind. When working in a utility room, it would not be safe for a dual technology sensor to shut the lights off when unable to detect a worker kneeling behind a water pump. This project used LED lighting to achieve its energy efficiency, but a process known as Value Engineering (initiated by the client) may force the lighting to revert to a fluorescent design. So to prepare for such a scenario, all of the LED lighting is circuited on the panel schedules at fluorescent lamp and ballast volt-amp loads. This process is safe and effective because LED lighting consumes a far less electric load. These loads are as follows (coordinate with light fixture schedule and floor plans): A1 = 72 VA, B1 = 72 VA, B2 = 105 VA, B4 = 72 VA, E1 = 72 VA, G2 = 32 VA, KH1 = 32 VA, NF1 = 32 VA, S1 = 32 VA, W1 = 72 VA, XA = 0 VA. The exit signs (XA) have a nominal consumption of less than one watt. The exit signs are still wired in accordance with their assigned branch circuit but do not factor into any load calculations as a typical practice.

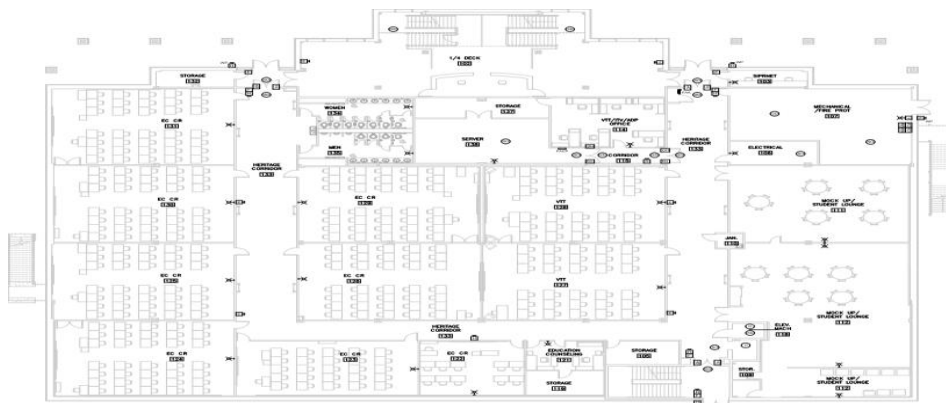

Fig. 12 First Floor Fire Alarm Plan

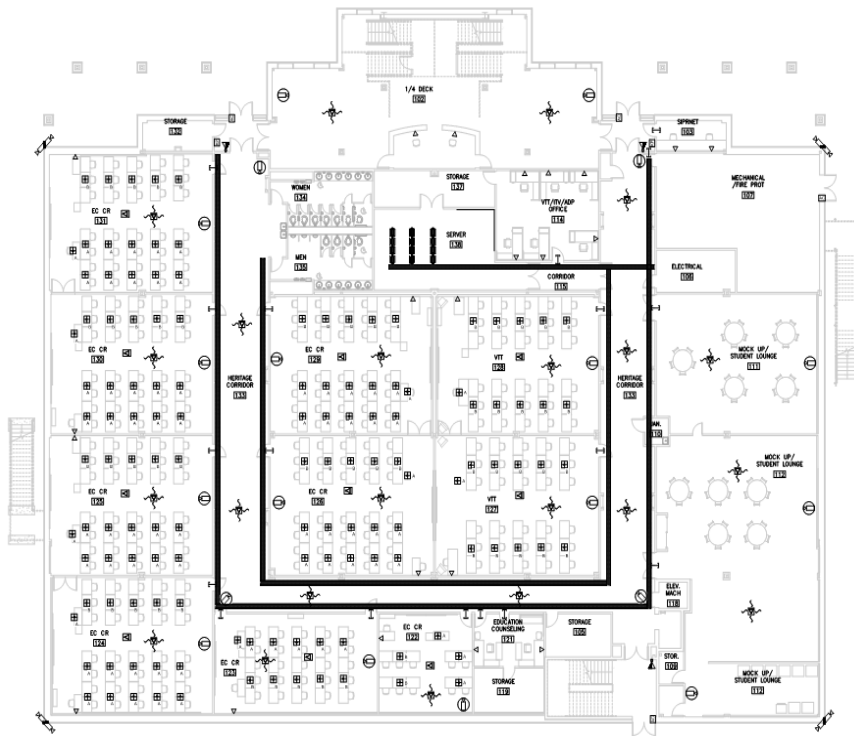

Fig. 14 First Floor Telecommunications Plan

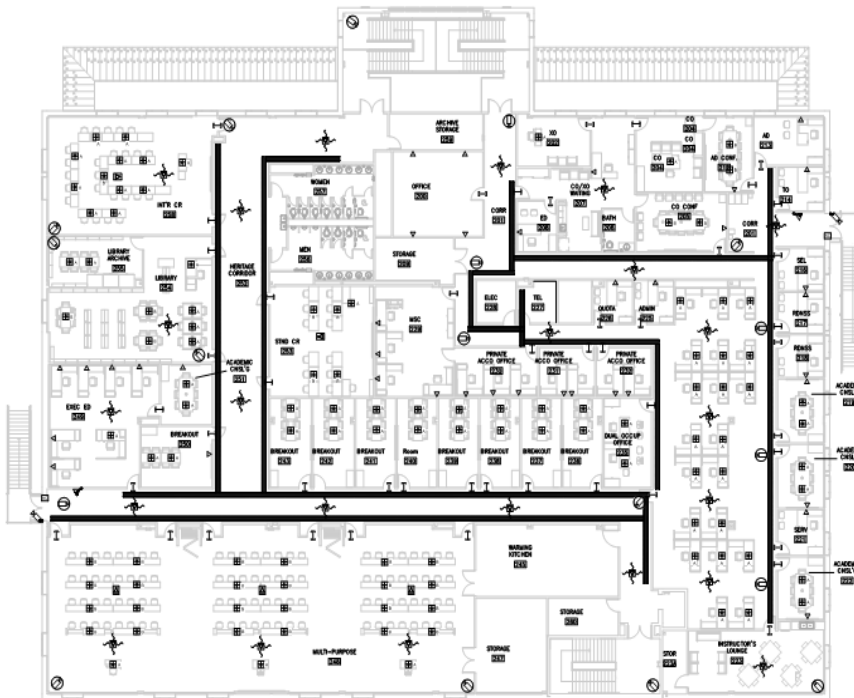







Fig. 15 Second Floor Telecommunications Plan

The equipment placed on the telecommunications floor plans are designed for Division 26 (Electrical Power) rough in only. Building owner shall supply all low voltage equipment, devices, and will be installed by a licensed low voltage contractor. All telecommunications distribution equipment and provisions that will require 120V supply has been circuited according to that floor's respective power plan and panel schedule.

The wiring methods for all telecommunications and low voltage equipment have been outlined in its respective technical specifications section. These schematic drawings outline tentative placement of cable tray, wireless access points, security cameras, intrusion detection devices, access card readers, and conduit sleeves for low voltage cabling into rooms. Provisions have been designed to provide wireless access to building occupants with an estimated usage of 35-50 devices per access point. The security and access system has been placed in an optimal configuration to achieve its desired performance. Final code compliance is reliant on the low voltage installer's installation and adherence to best practices, and will also bear full liability of the installation.

One of the last steps that can be completed independent of the circuiting of the building is the lightning protection system. Every year lightning strikes cause thousands of fires and billions of dollars in damages. The general concept of the system is very simple. There are terminals on the roof of the building that are made out of conducting material that the lightning strikes. These terminals are connected to main conductors that are all interconnected to the other air terminals. There are all connected to down conductors which carry all of the current to safely discharge into the ground. Although the general concept is simple there are numerous regulations and requirements for the system that must be met. There are two classifications for the lightning protection systems. A building either falls into class I or class II. The only difference in the difference classes are the materials used. Class I materials are used for buildings less than 75ft high and class II materials are used for buildings greater than 75ft. The building in this project uses class I materials.

There are other requirements besides the material requirements for the system. The air terminals must not be less than 10 in above the building. Most air terminals are placed 1ft above the roof level. There are different requirements for the type of roof. Pitched, sloping, dormers, domed, and roofs with chimneys or vents are all defined and the requirements are all explicitly stated in the NFPA code. The distance between air terminals must not exceed 20ft. If the building exceeds 50ft in width or length then there will be air terminals placed in the center of the building. Each terminal will have at least two pathways to a grounding conductor. Each building structure must have at least two down conductors. Depending on the size of the building there might be requirements for more down conductors and more regulations for roof and cross-run conductors. The building in this project has cross-run conductors and is greater than 50ft across so extra rows of air terminals are placed on the center of the structure. Each grounding conductor is connected with a grounding rod. The grounding rod length must be longer than 8ft and free from any nonconductive coating. They will be placed into the earth and extend no less than

LEGEND: (THIS SHEET ONLY)	
	CLASS I MAIN CONDUCTOR ON ROOF
	CONNECTION TO GROUND ROD (UNDER FOOTING)
	LIGHTNING POINT
	GROUND ROD
	CLASS I MAIN CONDUCTOR BELOW GRADE

10ft. Displayed Below is the diagram for this buildings lightning protection system.

Fig. 16 Lightning Protection System Legend

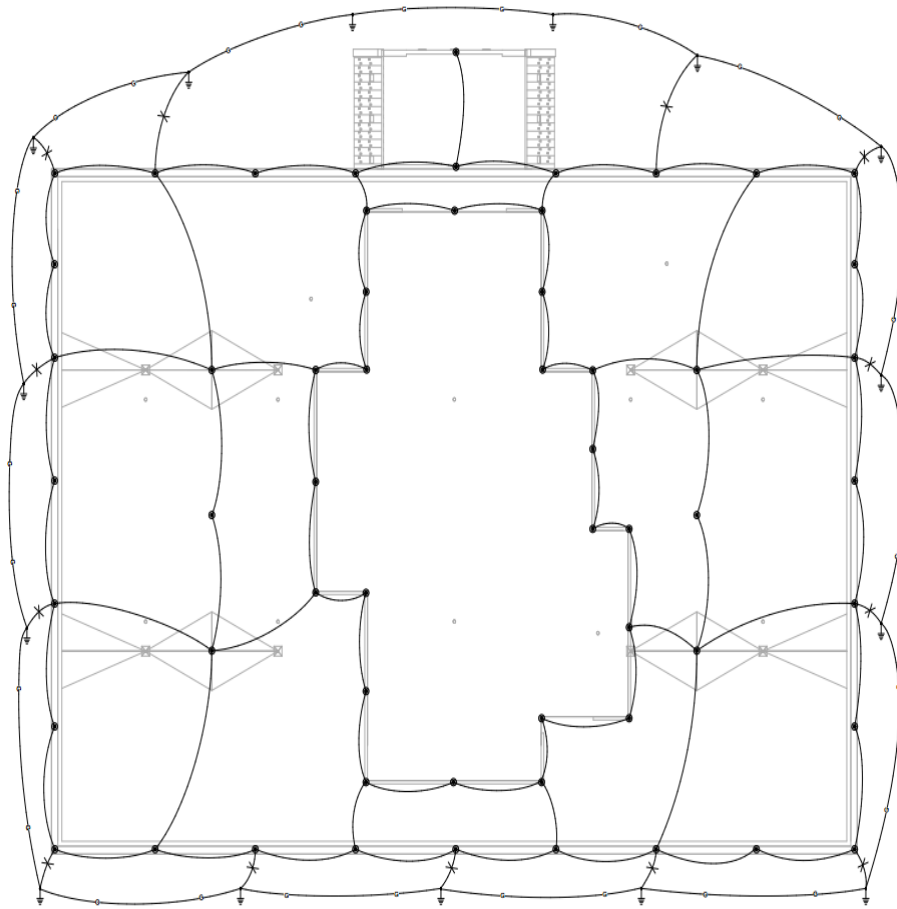

Fig. 17 Lightning Protection System

This figure shows that all the air terminals are spaced no more than 20 ft apart. Every air terminal has at least two pathways to discharge a lightning strike. There are cross-run conductors because the length is greater than 150ft. There are grounding conductors at all required spacing given in the NFPA code. All of the grounding rods are interconnected under the ground as per regulation. Refer to sheet E-302 for lightning protection system specifications.

V. CONCLUSIONS

The overall result of the project was a satisfying one. We were able to produce an extremely polished product for an energy efficient electrical design of a higher education building as well as layout for low voltage systems. We took a systematic approach where we tackled each portion of the project head on. We encountered many challenges and overcame all of them. We chose a building design and then chose all of the components that would be a realistic representation for a building in the real world. We produced an energy efficient design that beats all energy standards set by ASHRAE as well as met all code required by the NFPA and NEC. Below is a 3D isometric view of our building that displays just how many components and lights were placed.

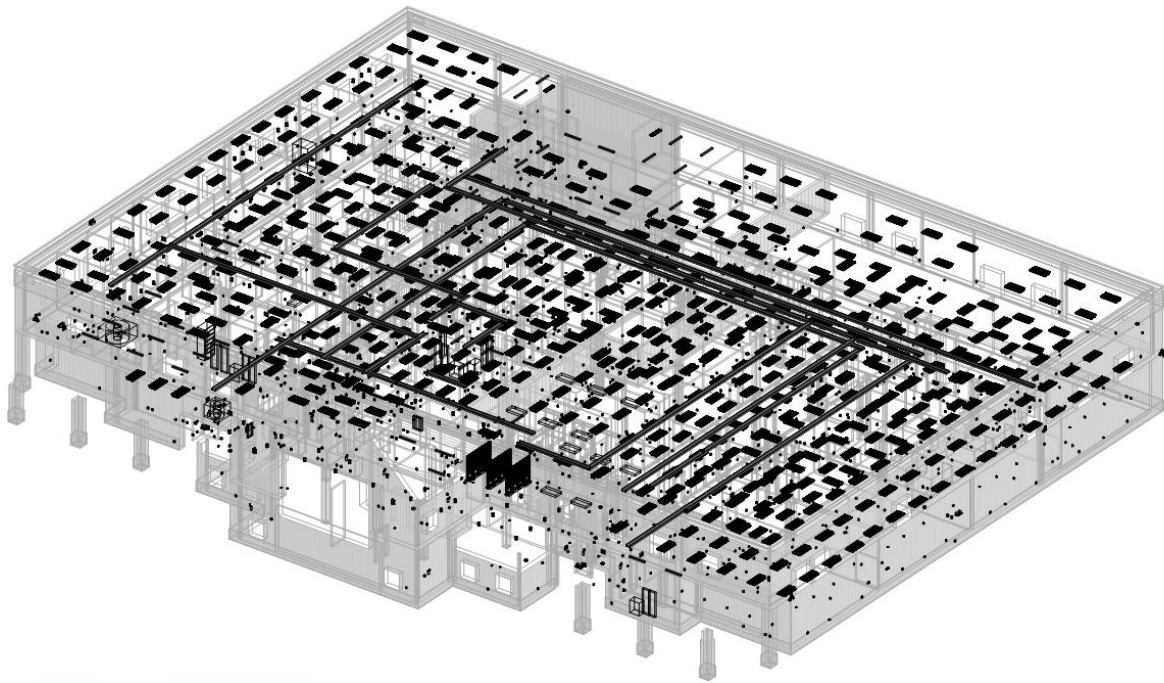

Fig. 18 3D Isometric Electrical View

VI. REFERENCES:

1. National Fire Protection Association, NFPA 72: Fire Alarm and Signaling Code, 2013
2. National Fire Protection Association, NFPA 101: Life Safety Code, 2015.
3. National Fire Protection Association, NFPA 110: Standard for Emergency and Standby Power Systems, 2013.
4. National Fire Protection Association, NFPA 780: Standard for the Installation of Lightning Protection Systems, 2014.
5. American Society of Heating, Refrigeration, and Air Conditioning, Standard 90.1: Energy Standards for Buildings Except Low-Rise Residential Buildings, 2013.
6. B. I. C. S. International, "BICSI: Advancing the Information and Communications Technology Community," [Online]. Available: <http://www.bicsi.org>. [Accessed 29 March 2015].
7. J. Hauck, Electrical Design of Commercial and Industrial Buildings, Jones and Bartlett Publishers, 2011.
8. T. Wildi, Electrical Machines, Drives, and Power Systems, Prentice Hall, 2005.
9. Building Industry Consulting Services International, Telecommunications Distribution Methods Manual 14th Edition, 2014.
10. D. DiLaura, K. Houser, M. Richard and G. Steffy, The Lighting Handbook, Illuminating Engineering Society of North America, 2011.
11. D. Bokmiller, S. Whitbread and D. Morrison, Mastering Autodesk Revit MEP 2015, Sybex Publishing, 2014.
12. National Fire Protection Association, NFPA 70: National Electric Code, 2014.
13. Q-cad.com, 'Revit Sample Files | 3D Revit BIM Samples | Q-CAD.com', 2015. [Online]. Available: <http://www.q-cad.com/samples/revit-3d/revit-3d-samples/>. [Accessed: 27- Apr-2015]